

ZWICK
ARMATUREN GMBH 

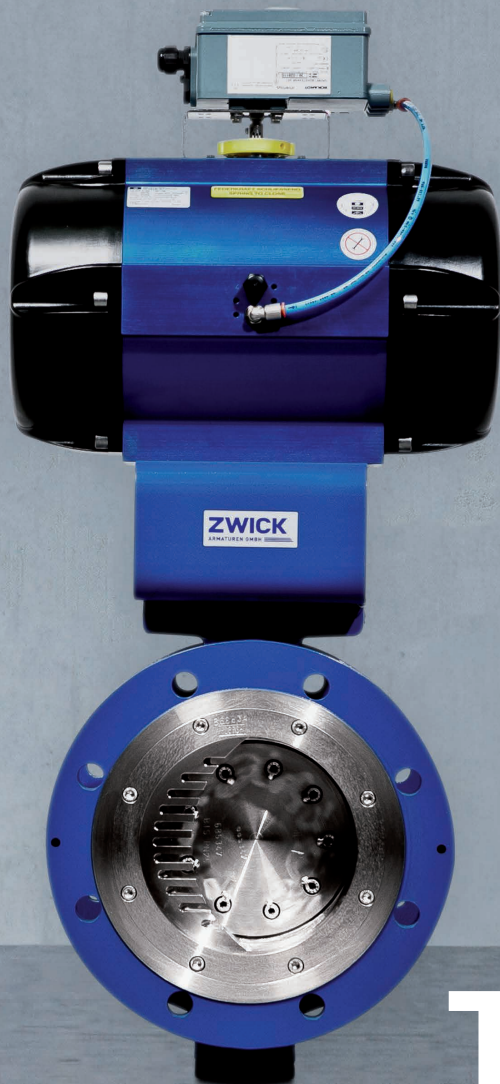

TRI-SHARK

100 % CONTROL VALVE **100% TIGHT**

08/19/2019

HIGH STANDARD VALVES FOR NON-STANDARD CONDITIONS.

TRI-SHARK Control Valves

TRI-SHARK control valves are able to achieve a nearly equal percentage inherent characteristic which greatly extends the control rangeability. Furthermore they offer great advantages in the field of cavitation reduction and noise attenuation, as well as in dynamic torque reduction.

They are suitable for a wide range of services, from cryogenic temperatures till -196°C up to $+815^{\circ}\text{C}$, including liquids, gases and steam.

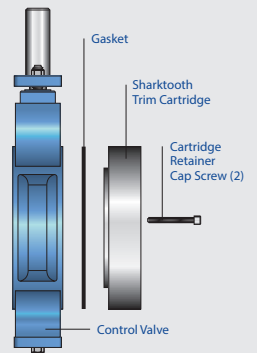
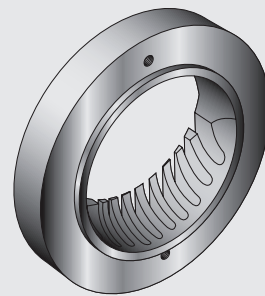
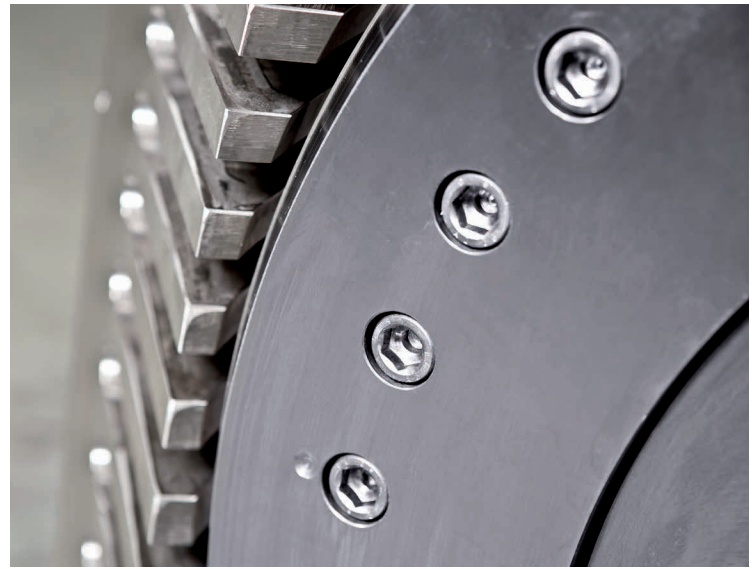

TRI-SHARK Throttling Trim Cartridge

The Sharktooth "Throttling Trim Cartridge" is used to turn our Triple-Off-Set Butterfly Valves into excellent throttling control valves. Now, just one style of valve can be used for both on-off, and control applications.

TRI-SHARK... controlling at every angle!

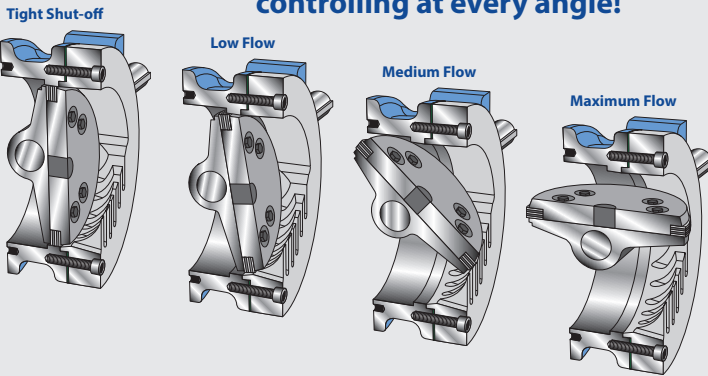

Performance Benefits

- DN 80 - DN 900, 3" - 36"*
- Class: 150 thru 900
- Carbon Steel, Stainless Steel, & Exotic Alloys
- Metal-to-Metal Seating
- Cryogenic to 815°C .
- Firesafe to API 607
- Low Running Torques
- Stable Control
- Light Weight
- Compactness
- Low Cost of Ownership
- Field Replaceable Trim Cartridges
- Zero Leakage
- Severe Service Capability

* = Larger sizes available



ZWICK

ARMATUREN GMBH

Egerstr. 1 & 25
D-58256 Ennepetal
TEL +49 (0) 23 33 / 98 56 5
FAX +49 (0) 23 33 / 98 56 6
MAIL info@zwick-gmbh.de

WWW.ZWICK-VALVES.COM